

Laguna Mist



Dimensions

Length: 76.5" (194.5 cm)
 Width: 29" (73.5 cm) or 32" (81 cm)
 Height: from 18" (45.5 cm) to 30" (76 cm)
 Cushion padding: 3" (7.6 cm)
 Lift capacity: 800 lb. (363 kg)

Options

Footswitch for 3 motors (416851)
 Auto-locking casters (412275)
 Crescent shaped headrest (412659)
 Ergonomic swivel armrest (right) - (412290)
 Ergonomic swivel armrest (left) - (412290)
 Arm cradle (412285)
 Paper holder (412609)

Dimensions

Length: 76.5" (194.5 cm)
 Width: 29" (73.5 cm) or 32" (81 cm)
 Height: from 18" (45.5 cm) to 30" (76 cm)
 Cushion padding: 3" (7.6 cm)
 Lift capacity: 800 lb. (363 kg)

Upholstery Options

Available in multiple upholstery color options to match every décor

Features

Rounded cushions at each end for better ergonomics
 Smooth quiet motor operation
 Handheld electronic control for easy and accurate positioning (backrest, seat, footrest and height)
 Electrically adjustable height – min.: 21.5" (54.5 cm) max.: 38.5" (98 cm)
 Luxurious upholstery system that combines high quality, fire-resistant, easy maintenance fabric with extra thick, high density, ultra comfortable 3" (7.6 cm) foam padding
 Stability and power to lift clients of all sizes 800 lb. (363 kg)
 Structurally reinforced backrest
 Easily accessible for people with disabilities when in a low position 21.5" (54.5 cm)
 14-gauge steel base with adjustable feet for stability
 No welding on hinges

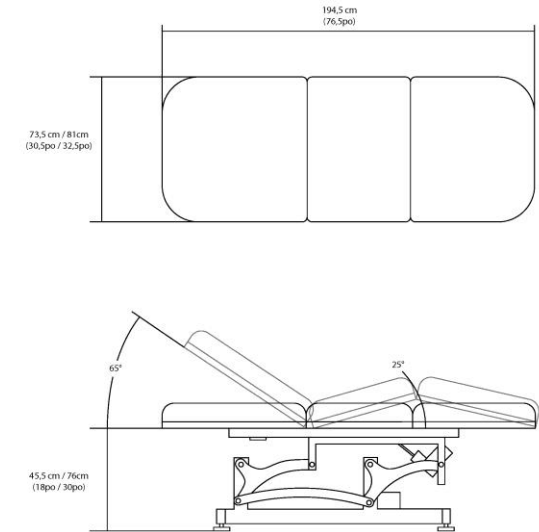

The Laguna Mist is a top pick amongst estheticians and massage therapists. Versatile and comfortable, it is designed for a wide range of therapies and treatments. Fully adjustable with a simple hand held remote, your clients will be swept off their feet by the comfort of this bed. The noiseless system with 3 quiet motors ensures a relaxing atmosphere. Every adjustment is smooth and quiet.

ITEM CODE: 41200 (29"), 412012 (32")
SOURCE FOR PURCHASE: SILHOUET-TONE USA 1623 NW 84 th Ave Miami, Florida 33126 1.800.552.0418 stusa@silhouettone.com
Warranty: See full warranty at www.silhouettone.us Wood, metal: 5 years, manufacturing defects. Upholstery, foam: 3 years, manufacturing defects. All motors: 2 years
Certifications: RoHS Certified. Our furniture is free from all lead and mercury. ISO 9001 & ISO 1345 Certified.
Country of Origin: Canada
Assembly: No assembly required.